



CASC

CINCINNATI ABRASIVE SUPPLY CO.

Vibratory Combo Finisher/Dryer

Since 1965, the founders of CLM VIBETECH, Inc. have produced, serviced, repaired and restored Vibratory Equipment. Drawing on the experience from working on almost every brand of vibratory machines, CLM VIBE TECH Inc. has designed a full line of vibratory equipment using the best features available in today's industry. As a customer said after seeing all the brands in the plant for repair, "Looks like you build the best and fix the rest". That statement is very true. From the inside out our machines are built with experience.

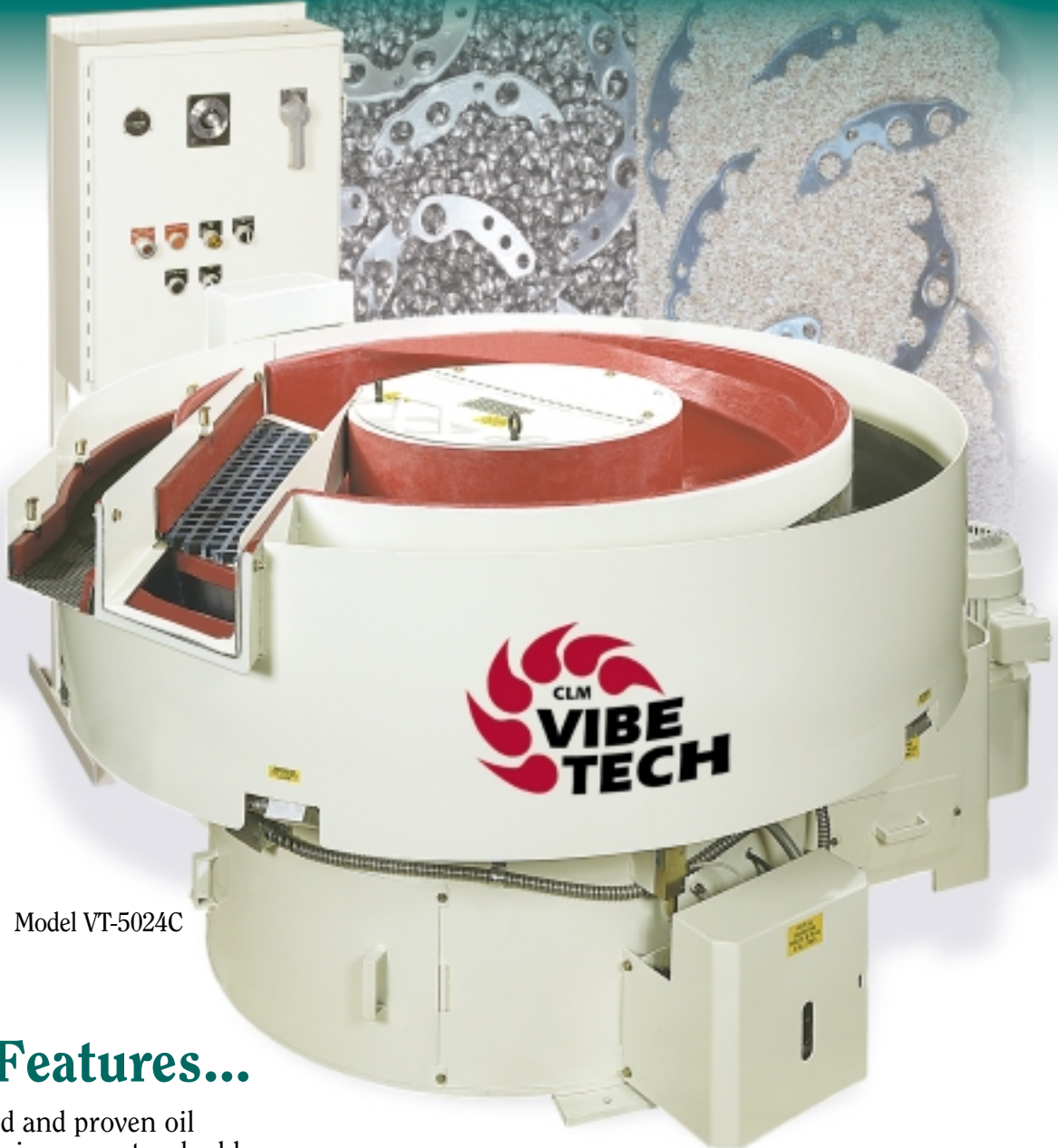

Model VT-5024C

Unbeatable Features...

- Industry's best designed and proven oil lubricated drive system incorporates double-row spherical bearings, large heavy-duty shaft and a thick-walled cartridge. (Grease lubrication system on small capacity models.)
- All heavy-duty welded construction.
- Minimum 1" thick premium polyurethane lining (three grades available including hot pour).
- Exterior mounted components provide easy access for maintenance and service.
- Extra large springs for durability.
- Most items needed for maintenance are available locally or on our shelf. We have the fewest custom made parts in the industry.
- Control panels are built to our customers requirements, from simple push button starters to fully automated PLC controls with digital displays.
- Process channel is heated directly from the bottom, distributing heat more evenly than standing heat lamp assemblies.
- Cool-down timer allows machine to run while cooling at end of cycle, eliminating scorching and cobb deterioration.
- Dust covers and dust collectors can be designed for any system.

Designed better to last longer..

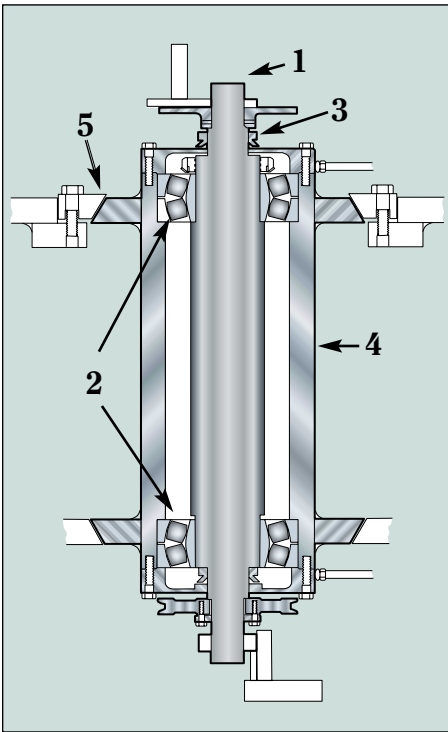

The heart of our oil lubricated vibratory combo finisher/dryer is the drive cartridge...

1. Heavy-duty, over-sized, precision machined drive shaft.
2. Highest quality double-row spherical bearings are fitted to drive shaft, with clearance to allow for heat expansion, unlike pressed bearings that can build-up heat and reduce bearing life.
3. Lightweight non-abrasive seals will never damage shaft.
4. For service, our extra-heavy walled cartridge is the most easily accessible and removable cartridge in the industry.
5. Tapered drive clips are pulled down with grade 9 bolts, superior to relying on bolt shear strength.

The conical structure and the center tube are designed to optimize the transfer of energy from the drive cartridge to the process channel by distributing it correctly and without unnecessary stress to the structure.

Options:

- Pneumatic Gates • PLC Automation
- Rinse Bars • Media Classifying
- Dust Collectors • Regenerative Blowers
- Step-down Screens • Gate Clearing
- Noise and Dust Covers • Variable Speed
- Air Knife • Settling Tanks
- Shaker Screeners • Material Handling

Accessories for all makes:

- Drains • Gates • Compound System
- Screens • Noise and Dust Covers

Services:

- **Process Evaluation:** send us your sample parts for a free process evaluation.
- **System Design:** we can design and build custom systems from simple batch processes to fully automated systems.
- **Vibratory Equipment Repair:** we service all makes and models of vibratory equipment from basic repair to complete restoration.
- **Relining:** on all makes and models, 3 grades of urethane available from cold to hot pour.

For Service Call... 1-800-741-0670

Specification and Dimensions

Model	VTG-3816C	VTG-5024C	VT-5024C	VT-5524C	VT-6026C	VT-6830C	VT-7230C	VT-8844C
Capacity (cu. ft.) Dryer/Finisher	3.8 / 1.7	7 / 5	7 / 5	9.5 / 7	13 / 10	19 / 14	24 / 17	36 / 25
Motor Hp (A)	3	5	5	7.5	7.5	15	15	20
No. of drains	2	2	2	2	2	2	2	3
Lubrication system (C)	Grease	Grease	Auto Oil	Auto Oil	Auto Oil	Auto Oil	Auto Oil	Auto Oil
Discharge height (D)	31"	34"	34"	35"	37"	44"	44"	56"
Finisher Channel width (F)	9.5"	11"	11"	13.5"	15"	17.5"	19"	20"
Dryer Channel width (G)	5"	8"	8"	8"	10"	10"	12"	14"
Overall diameter (H)	48"	66"	66"	71"	80"	88"	96"	116"
Overall height (E)	36"	42"	42"	43"	44"	53"	53"	64"
Floor space required	4' x 4'	6' x 6'	6' x 6'	7' x 7'	8' x 8'	9' x 9'	10' x 10'	11' x 11'

Due to on going design improvements, design and specifications are subject to change without notice.

In addition to our line of Combo Finisher/Dryers we have a full line of; Vibratory Finishers, Vibratory Dryers, Long Radius Finishers; for excellent steel ball burnishing and longer cycle times, can be set up for continuous operations, Helix Finishers; for continuous operations, Tub Finishers; for batch processes

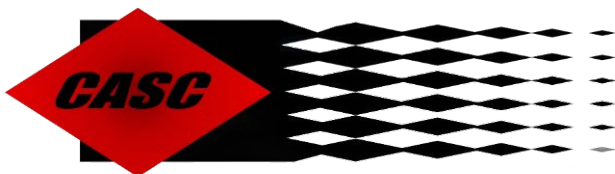
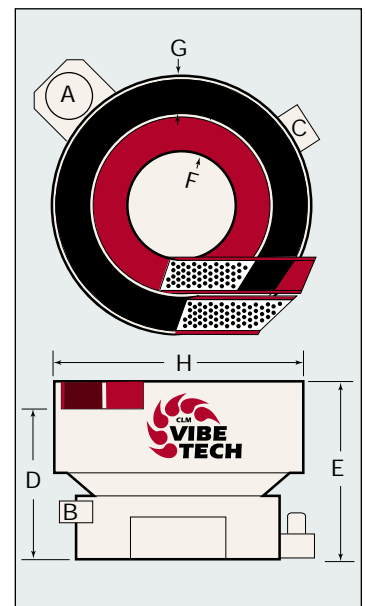

CINCINNATI ABRASIVE SUPPLY CO.

9431 Sutton Place
Hamilton, OH 45011
Ph: 513-914-8866 Fax: 513-941-8963